



Product Instructions

PNEUMATIC MAGNET IXTUR MAP-120R

Original User Manual

Content

- Introduction and Warnings 2
- Technical Specifications 3
- Holding Force 4
- Installing the Device 7
- Using MAP-120R Pneumatic Magnet..... 8
- Maintenance and Inspections 8
- Warranty 8
- Patent Pending..... 9
- Declaration of Conformity 9

Introduction and Warnings

MAP-120R is a pneumatic magnet meant for attaching ferromagnetic parts in lifting, work holding or automation applications. This model is optimized for parts that do not fully cover the magnet's gripping surface, e.g. tubes and axles. The magnet's state, attached or detached, is changed pneumatically. MAP-120R pneumatic magnet doesn't need pressurized air to keep its state. Air pressure is needed only to change the state from attached to detached or vice versa.



- Please read this manual carefully before deployment to ensure safe use of the device.



- This device includes a source of magnetic field. A fluctuating magnetic field is produced during the use in the proximity of the device.



- The magnets of the lifting beam produce magnetic fields that may interfere with medical devices such as metallic implants or cardiac pacemakers. Refrain from using the lifting beam and keep out of close proximity unless you have approval from the manufacturer of your medical device or from your physician.



- Do not disassemble or replace the device parts. Only pneumatic connectors are user changeable.
- The device must not be used for lifting or transporting people.
- Always pay special attention to the factors that may decrease the holding force of the magnet.
- The permitted holding force must not be exceeded.
- Do not operate a damaged or malfunctioning device.
- The designer and manufacturer of the whole system should always ensure that the system where this device will be integrated to meets local and national safety regulations.

Technical Specifications

Dimensions:

- Height: 82.0 mm (98.0 mm including pneumatic connectors)
- Diameter: 120.0 mm
- Weight: 5.7 kg

Capacity:

- Holding force for flat: minimum 3.53 kN (S355 S \geq 25 mm)
- Holding force for round object: minimum 2.06 kN (S355 $\varnothing \geq$ 240 mm)
- Rated lifting capacity for flat with safety factor 3: 120 kg (S355 S \geq 25 mm)
- Rated lifting capacity for round object with safety factor 3: 70 kg (S355 $\varnothing \geq$ 240 mm)
- Residual holding force: maximum 60 N

Environmental conditions:

- Operating temperature: 0 °C ... +50 °C
- Storage temperature: -20 °C ... +50 °C
- Humidity 0 % ... 90 %
- IP67 (The product is protected from dust and temporary immersion up to 1 m)

Requirements for compressed air:

- Recommended pressure: 6.0 bar
- Functional range: 5.0 ... 8.0 bar
- Water separating
- Particle filtering \leq 5 μ m

Information related to medical implants

- Safety distance for a person with active implanted device is 50 cm of air or other non-magnetic material. The distance is measured from the magnet or magnetic material attached to it.
 - o *Maximum static magnetic field of MAP-120R is 220 mT on the gripping surface.*
 - o *Interference with active implanted devices, e.g. cardiac pacemakers – Action level for exposure to static magnetic fields is 0,5 mT [Directive 2013/35/EC].*

Holding Force

Holding force and rated lifting capacity of MAP-120R can only be applied when the forces are perpendicular to the magnet's gripping surface.

Four factors affect magnet's holding force:

- Material properties
- Thickness of the load
- Distance between gripping surface and attached load (airgap)
- Object diameter when lifting round part

Holding force and lifting capacity of MAP-120R pneumatic magnet are rated with steel EN S355. Most other steel materials produce lower holding force. Also hardened steel produces lower holding force.

Material's capacity to conduct magnetic field depends on its thickness. A thinner material has weaker capacity compared to a thicker material. Increasing material thickness increases the material's capability to conduct magnetic field until a magnet specific maximum value is reached. See figure 2: *MAP-120R holding force in proportion to material thickness*

Any material that separates the magnet's gripping surface from the surface of the load reduces the total magnetic holding force. Reduction can be caused by non-magnetic materials or by materials with weak magnetic qualities, such as, zinc or paint or similar coating, rust, frost or air. The distance between the surfaces caused by materials above is commonly called as airgap.

Surfaces must be clean and the airgap zero to achieve maximum holding force. The load surface must also be flat and it must occupy the gripping surface of the device completely. See figure 3: *MAP-120R holding force in proportion to airgap*.

MAP-120R is optimized for parts that do not fully cover the magnet's gripping surface, e.g. tubes and axles. When the lifted load does not fully cover the gripping area of MAP-120R, it is important that the load at least partly covers both of MAP-120R's magnetic poles.

In case of round parts, the magnet's holding force depends also on part's diameter. Rated holding force can be achieved with \varnothing 240 mm. See figure 4: *MAP-120R holding force in proportion to round part diameter*. The graph in the figure is valid for a round part made of solid material.

Gripping surface - Magnetic poles

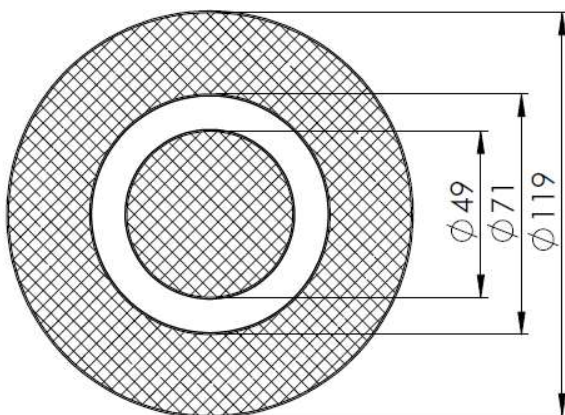

Figure 1. The gripping surface and magnetic poles of MAP-120R.

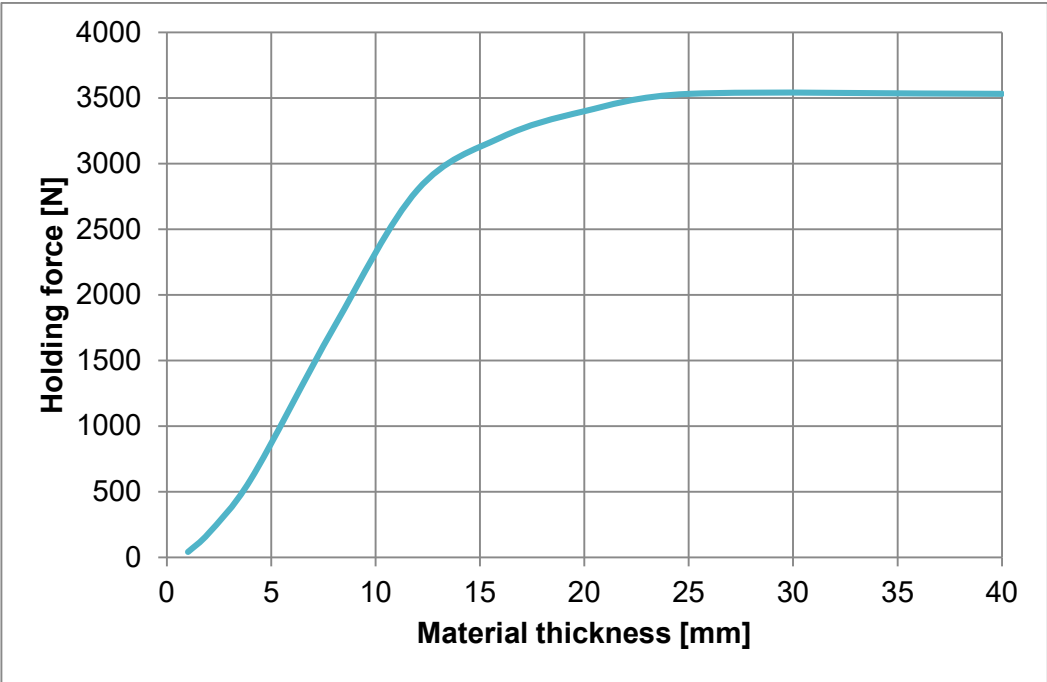

Figure 2. MAP-120R holding force in proportion to material thickness

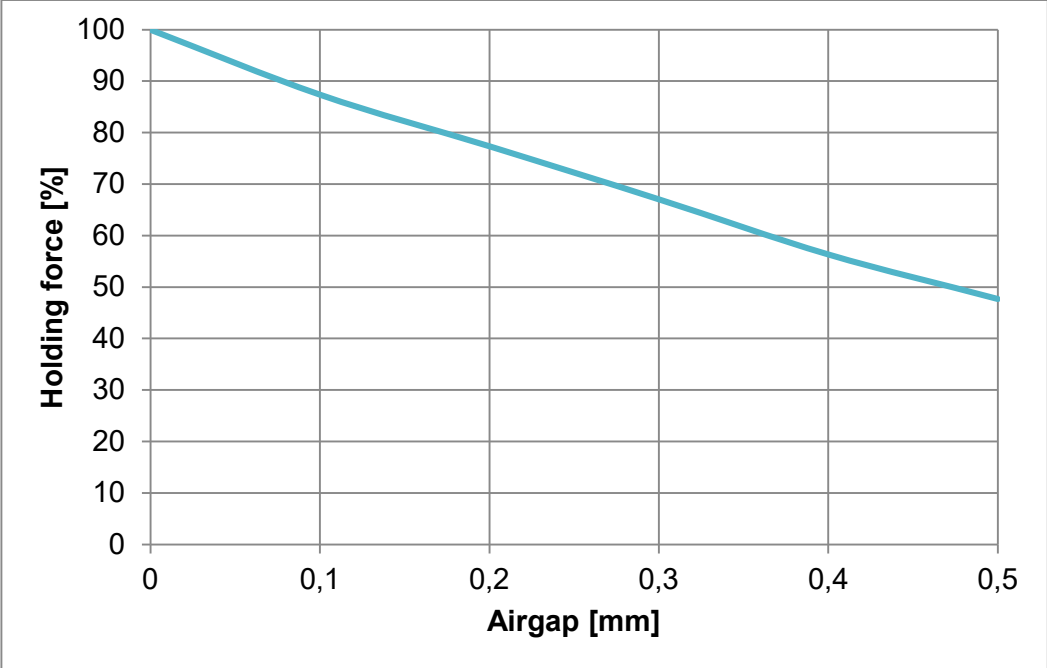

Figure 3. MAP-120R holding force in proportion to airgap

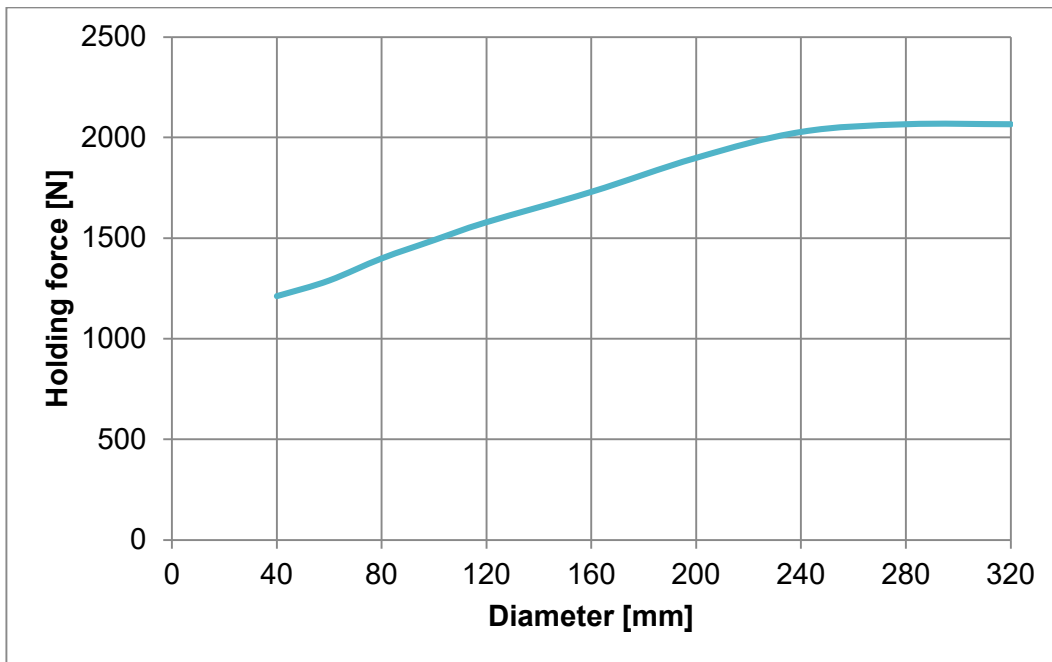

Figure 4: MAP-120R holding force in proportion to round part diameter

- ⚠ The holding forces specified in this document are valid for steel EN S355. Most other magnetic material results in lower holding force.
- ⚠ The rated lifting capacities are valid for solid cylinders $\varnothing \geq 240$ mm or plates of ≥ 25 mm thick. Pipes, smaller cylinders or thinner plates lead to lower lifting capacity.
- ⚠ When lifting a piece from a stack, also the piece below the lifted piece can be attached to the magnet.
- ⚠ The forces caused by acceleration must be considered. For example, sudden moves cause stronger forces than slow and smooth moves. Sudden moves may drop the load.
- ⚠ Before magnet attachment, both the magnet's gripping surface and the load material surface must be cleaned of foreign materials to minimize the airgap that reduces the holding force.
- ⚠ Due to residual magnetism, the magnet's lifting surface may contain minor magnetic particles or pieces which reduce the holding force.
- ⚠ The load material surface may bend, which produces an airgap and reduces the holding force. Especially thin materials may cause this effect.
- ⚠ Do not lift the load higher than necessary. Unnecessary elevation of the load during lifting increases the risk of damage or injury.

Installing the Device

MAP-120R pneumatic magnet has to be installed using the M8 screws (3 pcs.) according to Figure 5. The pneumatic connections have to be made using 6.0 mm tube.

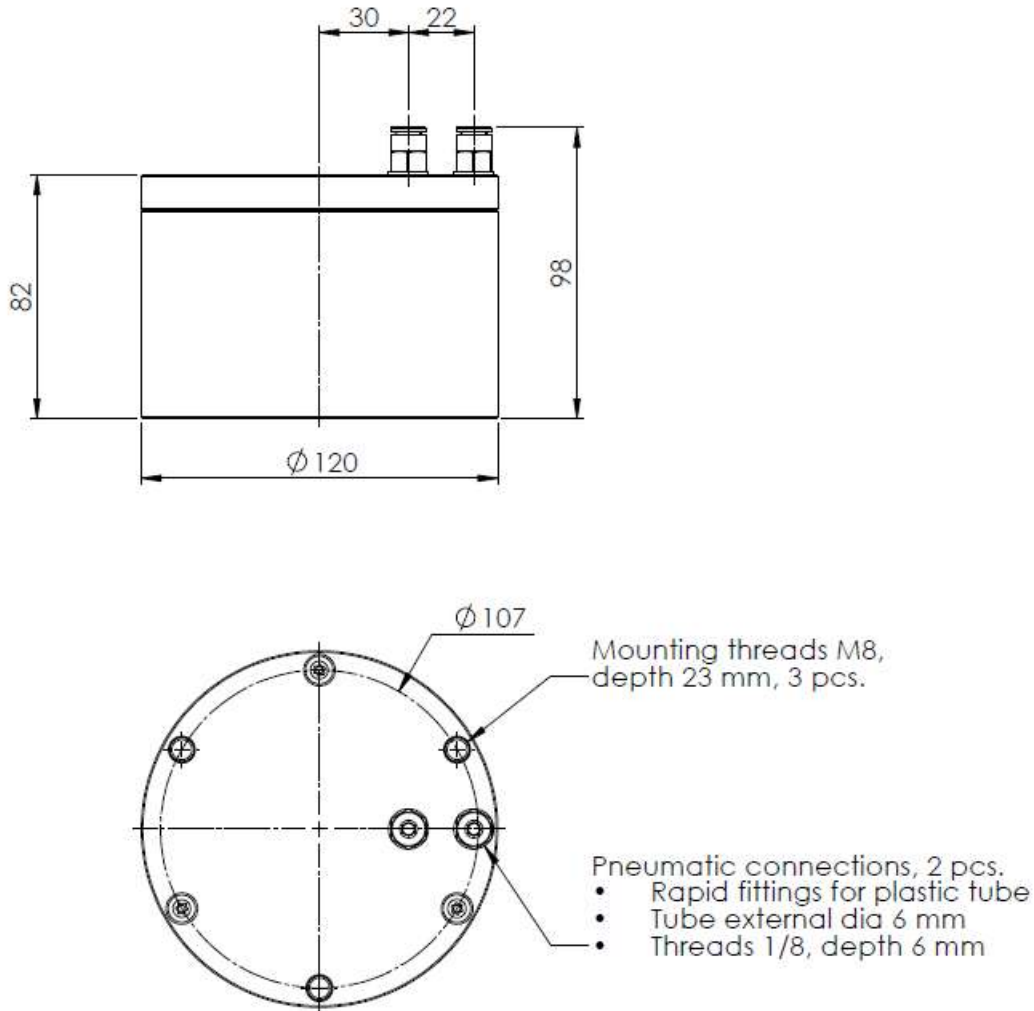

Figure 5: Mounting dimensions of MAP-120R.

Using MAP-120R Pneumatic Magnet

The top cover of MAP-120R pneumatic magnet has two pneumatic connectors. When air pressure is applied to the inner connector, MAP-120R is set ON (attach). When air pressure is applied to the outer connector, MAP-120R is set OFF (detach).

The same pressure in both air hose contacts or no pressure at all keeps the magnet's current state.

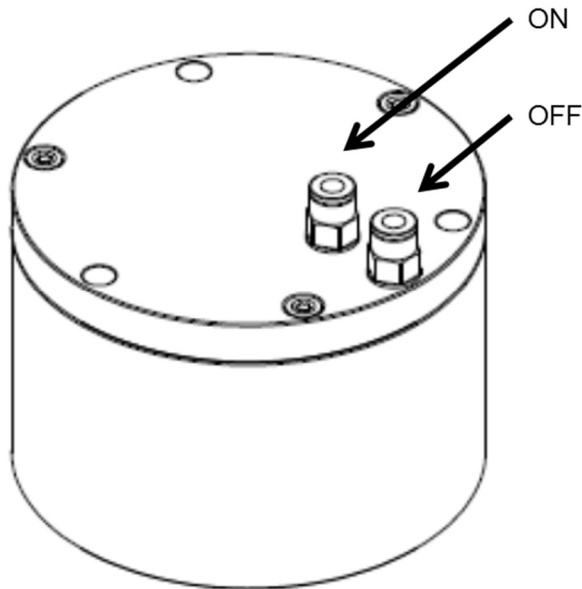

Figure 6: MAP-120R pneumatic connectors

Maintenance and Inspections

MAP-120R pneumatic magnet itself is maintenance free.

If MAP-120R pneumatic magnet has been dropped down or it has been exposed to some other impact, it must be inspected for any damages before continuing its use.

Do not use the device if you find any damages or malfunction!

Warranty

The product has a 12 months warranty from the date of delivery. The warranty covers material and manufacturing defects. Warranty does not cover defects caused by a misuse of the product against the instructions in this manual. The warranty does not cover normal wear and tear.

Patent Pending

Several patent applications are pending related to MAP-120R and Ixtur pneumatic magnet technology.

Declaration of Conformity

Declaration of incorporation of partly completed machinery

Directive 2006/42/EC

We hereby declare that this partly completed machinery, *Pneumatic Magnet MAP-120R*, complies with the essential requirements of the Directive 2006/42/EC on Machinery and the following harmonized standards have been applied and fulfilled:

- EN ISO 12100:2010
- ISO/TR 14121-2:2007
- EN 13155:2003+A2:2009

The technical documents of partly completed machinery are compiled in accordance with section B of Annex VII of Directive 2006/42/EC, that can be transmit, in response to a reasoned request by the national authorities.

Partly completed machinery must not be put into service until the final machinery into which it is to be incorporated has been declared in conformity with the provisions of the Directive 2006/42/CE on Machinery.

INCORPORATION OF PARTLY COMPLETED MACHINERY

Translation of the original

Directive 2006/42/EC

Ixtur OyVarespellontie 6
21500 KAARINA
Finland

Hereby declares that the following partly completed machinery

Description	Pneumatic magnet Gripper
Model	MAP-120R
ID number	A11B ...D99B

fulfills the following essential requirements of Directive 2006/42/EY:

- Annex I: 1.1.2 a, 1.1.3, 1.1.5, 1.3.2, 1.3.4, 1.5.10

The technical documents of partly completed machinery is compiled in accordance with section B of Annex VII of the Directive 2006/42/EC.

The following harmonized standards have been applied:

- EN 13155:2003+A2:2009
- EN ISO 12100:2010
- ISO/TR 14121-2:2007

All relevant information about the partly completed machinery will be transmitted by post or electronically, in response to a reasoned request by the national authorities.

Partly completed machinery must not be put into service until the final machinery into which it is to be incorporated has been declared in conformity with the provisions of the Directive 2006/42/CE.

Person authorized to compile the technical documentation:
Juho Suominen, Address: Varespellontie 6, FI-21500 Kaarina, Finland

The original document of this declaration is published in Finnish 24.4.2022

Place and date:

Kaarina 24.4.2022





Markku Oksanen
Managing Director
Ixtur Oy