

11/2016



**Ixtur MRP-170 is a pneumatically controlled neodymium permanent magnet that is suitable for gripping parts with different shapes.**

The magnet does not change its magnetic state in case of loss of compressed air.

The compact size combined with the strong gripping force provides high versatility. Ixtur MRP magnets are maintenance-free and have a short cycle time, allowing high production speed and efficient automation.

MRP-170 magnet is suitable for flat and round parts, and for both steel and cast iron. Ixtur magnets can handle solid and perforated material and they can be used in any orientation needed, so it's possible to handle objects with various shapes and angles.

### TECHNICAL SPECIFICATIONS

Lifting capacity WLL [kg]	Gripping capacity [kg] [kN]	Residual gripping capacity, max. [kg]	Dimensions L x W x H [mm]	Weight [kg]	Operating temperature [°C]	Air pressure: functional range [bar]	Pneumatic hose outer diameter [mm]	Minimum cycle time [s]
Flat: 170	510* 5,0*	7	103 x 120 x 140	11	0 ... 50	5 ... 8	6.0	< 1
Round: 120**	360** 3,5**	***						

\* plate thickness  $\geq$  25 mm

\*\* cylinder diameter  $\geq$  120 mm

\*\*\* see the paragraph 'Residual gripping capacity' below

The lifting capacities (WLL) are determined with a safety factor of 3.

### Residual gripping capacity

The residual gripping capacity, i.e. the gripping capacity when the magnet is OFF, varies based on the material and structure of the gripped part. In extreme cases, parts up to 30 kg may stay attached. The residual capacity is greatest as long as the part continuously stays in contact with the magnet after the magnet has been turned from ON to OFF. If the amount of residual capacity is critical to the application, pretesting with the actual part is recommended.

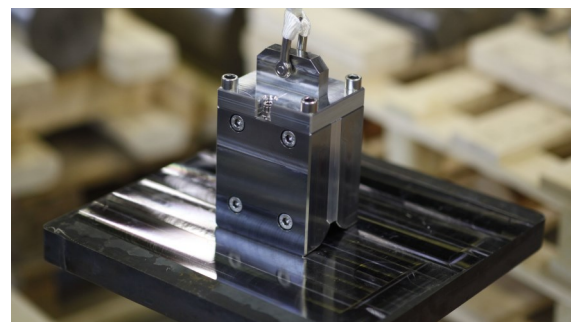

An MRP-170 magnet with a lifting adapter.

For cylindrical loads, the minimum diameter is 25 mm.

The magnet can be used in various applications: lifters, robot grippers, fixtures, production automation, etc.

More information: [www.ixtur.com](http://www.ixtur.com)

**Company** • Ixtur Ltd. is a Finnish magnet technology company established in 2010. Ixtur develops and manufactures permanent magnet based lifters, grippers and customer applications for machinery, welding, automation, robotics and material handling. Ixtur is focused on energy-efficient magnet components and applications.

**ixTUR®**

# MRP-170

## Pneumatic Magnet

### Gripping capacity vs. material thickness, diameter and airgap

The nominal gripping capacity can be obtained with plate thickness of  $\geq 25$  mm and with no airgap. The magnets can be used also with thinner materials, but the gripping capacity will be lower.

The given gripping capacities are valid for mild steel (S355).

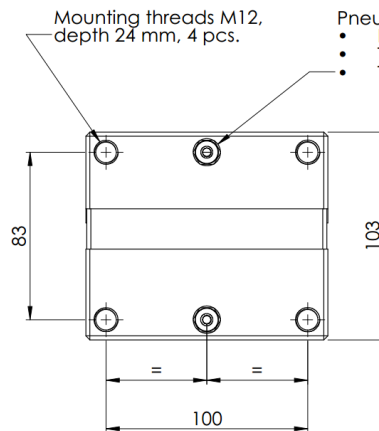
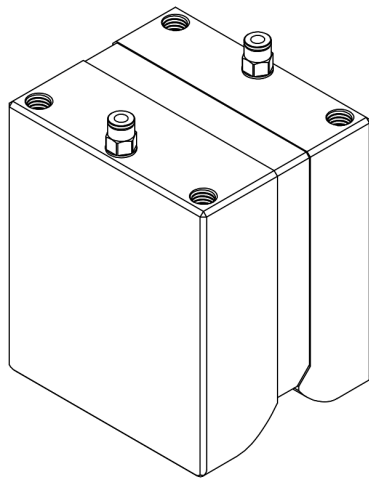
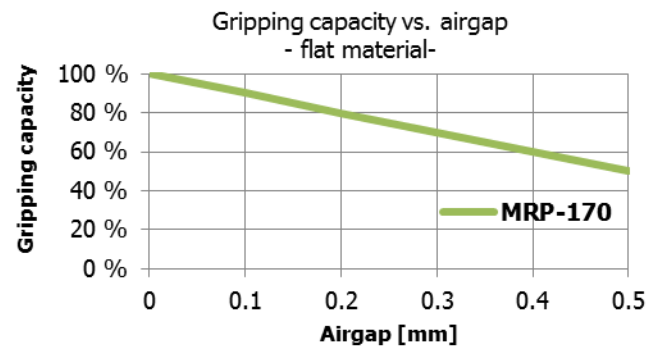
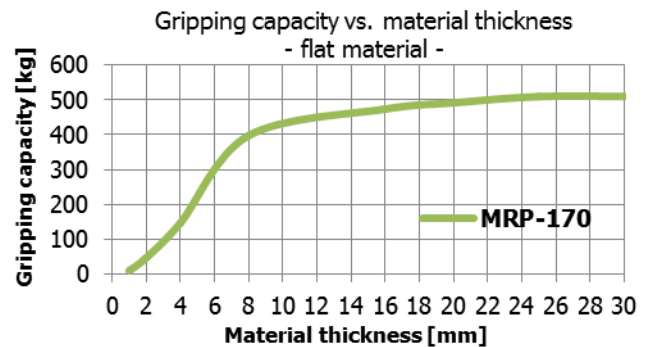
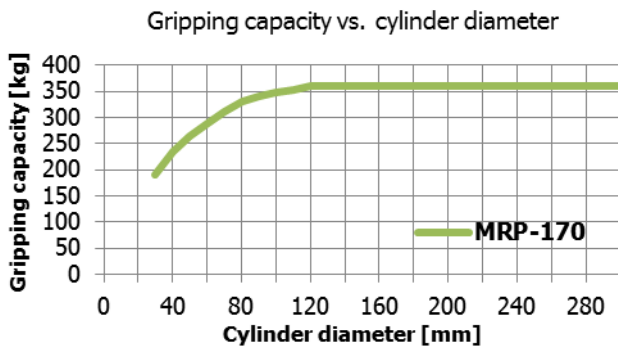

- Pneumatic connections, 2 pcs.
- Rapid fittings for plastic tubing
  - Tube external dia 6 mm
  - Threads 1/8, depth 10 mm

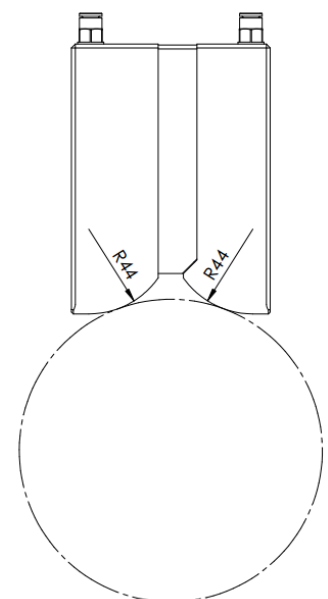
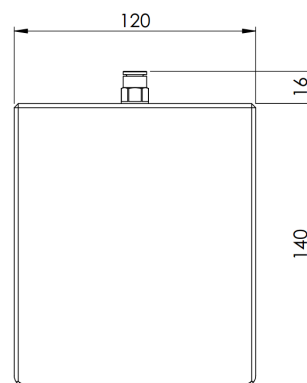
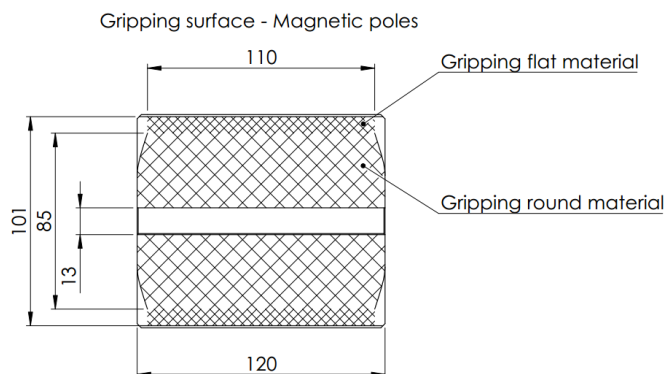

**Company** • Ixtur Ltd. is a Finnish magnet technology company established in 2010. Ixtur develops and manufactures permanent magnet based lifters, grippers and customer applications for machinery, welding, automation, robotics and material handling. Ixtur is focused on energy-efficient magnet components and applications.

**ixTUR®**